

Tee - 4 Prong Nut

Thread Type: UNC / BSW - Coarse

Thread Direction: Right Hand

Material: Carbon Steel

Class Grade: Low Tensile Grade 2

Finish: Zinc Plated

Corrosion Protection Level: Moderate

Comments: UNC and BSW have the same thread per inch value, except for 1/2"

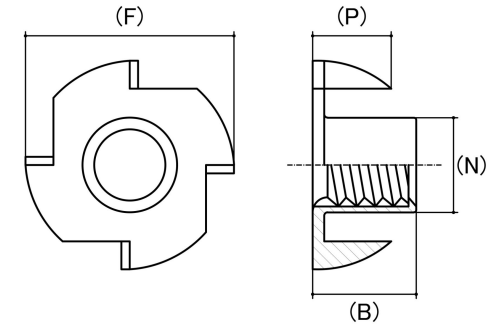

*Cad Drawings shown for graphic representation only.**

Size	Thread Pitch (TPI)	Thread Type	Overall Nut Height (B) (mm)		Flange Diameter (F) (mm)		Body Diameter (N) (mm)		Prong Height (P) (mm)		sku (Part Number)
			Min	Max	Min	Max	Min	Max	Min	Max	
3/16" (#10-24)	24 TPI	Coarse	7.70	8.00	17.80	18.20	6.15	6.25	6.50	6.70	41TW3168
1/4"	20 TPI	Coarse	8.20	8.50	17.80	18.20	7.40	7.60	5.10	5.30	41TW147
1/4"	20 TPI	Coarse	9.20	9.40	17.80	18.20	7.40	7.60	7.20	7.40	41TW149
5/16"	18 TPI	Coarse	9.80	10.20	21.80	22.40	9.15	9.30	7.60	7.80	41TW5169
5/16"	18 TPI	Coarse	10.80	11.20	21.80	22.40	9.15	9.30	7.60	7.80	41TW51611
5/16"	18 TPI	Coarse	16.80	17.20	21.80	22.40	9.60	9.80	9.00	9.20	41TW51616
3/8"	16 TPI	Coarse	12.00	12.60	24.80	25.40	10.90	11.30	8.50	8.80	41TW3812

Disclaimer:

Dimensional data and technical information was obtained from publically available sources and not acquired through standard agencies. It has been completed and compiled for reference purposes only; where discrepancies are found they are subject to change without notice. Bolt & Nut Australia makes no warranties or representations regarding the accuracy and validity of the compiled information and data. Contact the relevant standard authorities for accurate and detailed information.

* Cad Drawings may not reflect diameter, thread length or overall length.

© Bolt & Nut Australia Pty Ltd. All rights reserved.

Version: 25 Aug 2024